

NECK FINISH:	M24 SP410	GRAM WEIGHT:	30.0g±2.0g
BOTTLE MAT.:	PVC	OVER-FLOW:	397ml±11ml
DESC.	12oz. PVC VALE		



PROJECT NO.: 4-22202-P

SCALE: 3:4

REV.: D

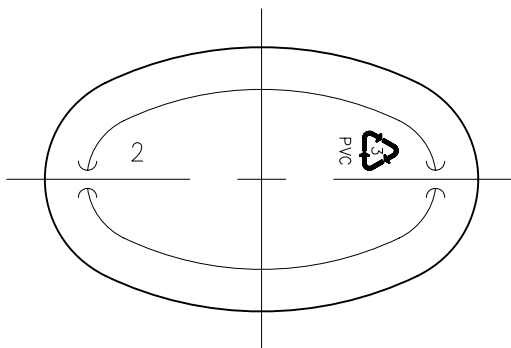
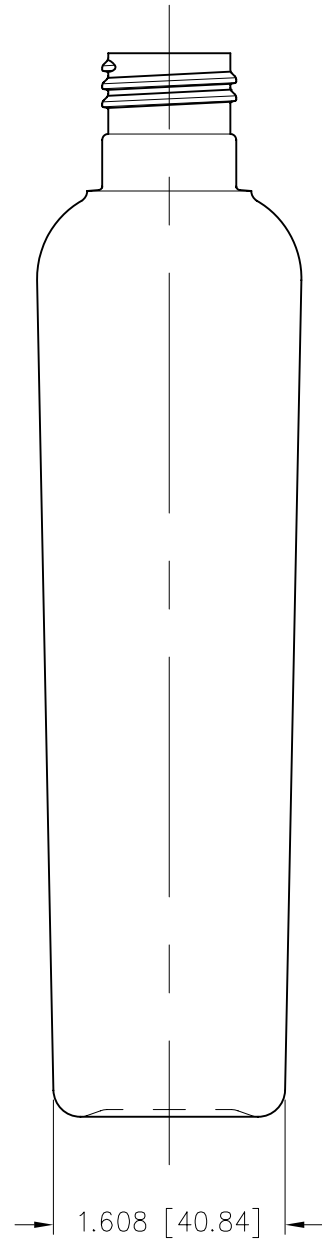
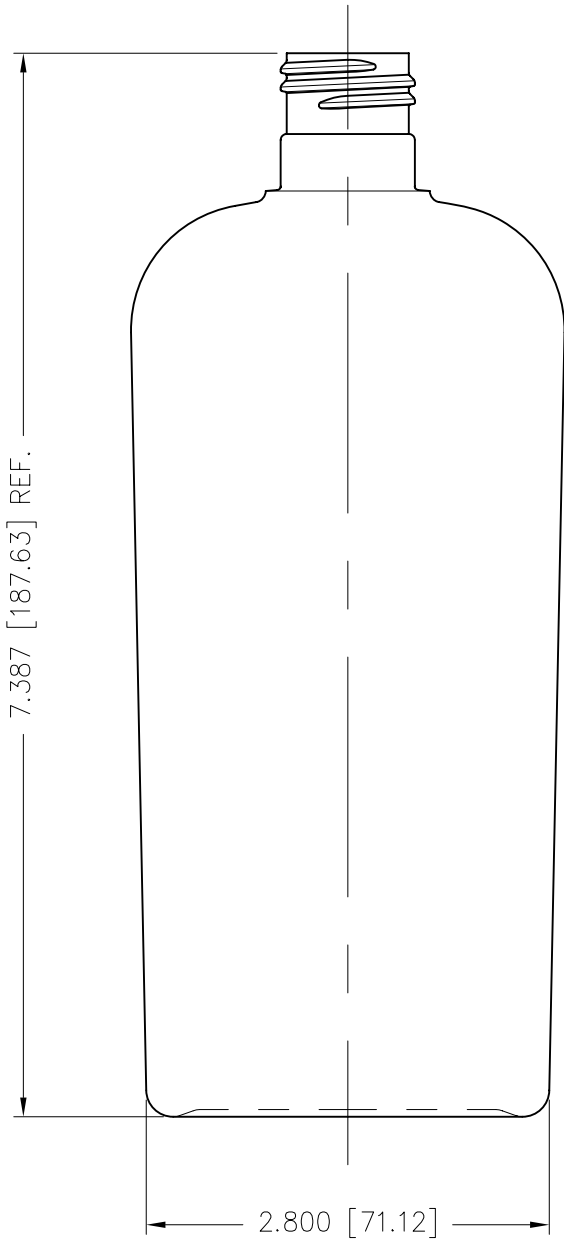

NECK FINISH:	M24 SP415	GRAM WEIGHT:	30.0g±2.0g
BOTTLE MAT.:	PVC	OVER-FLOW:	397ml±11ml
DESC.	12oz. PVC VALE		



PROJECT NO.: 4-22202-P

SCALE: 3:4

REV.: D

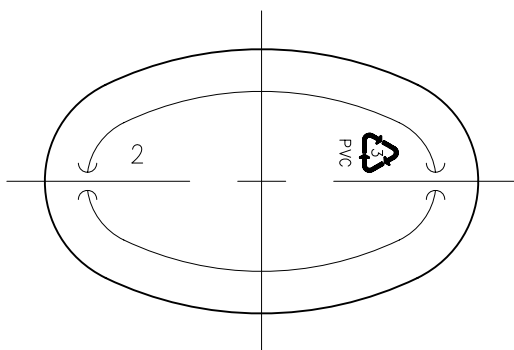
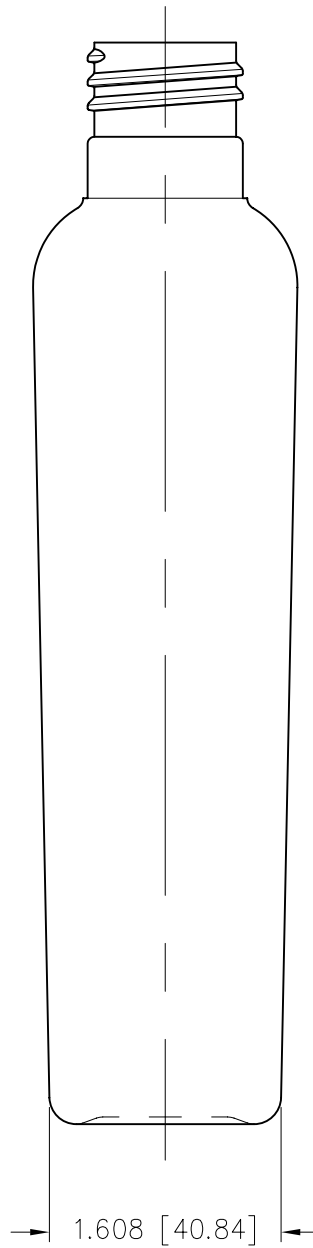
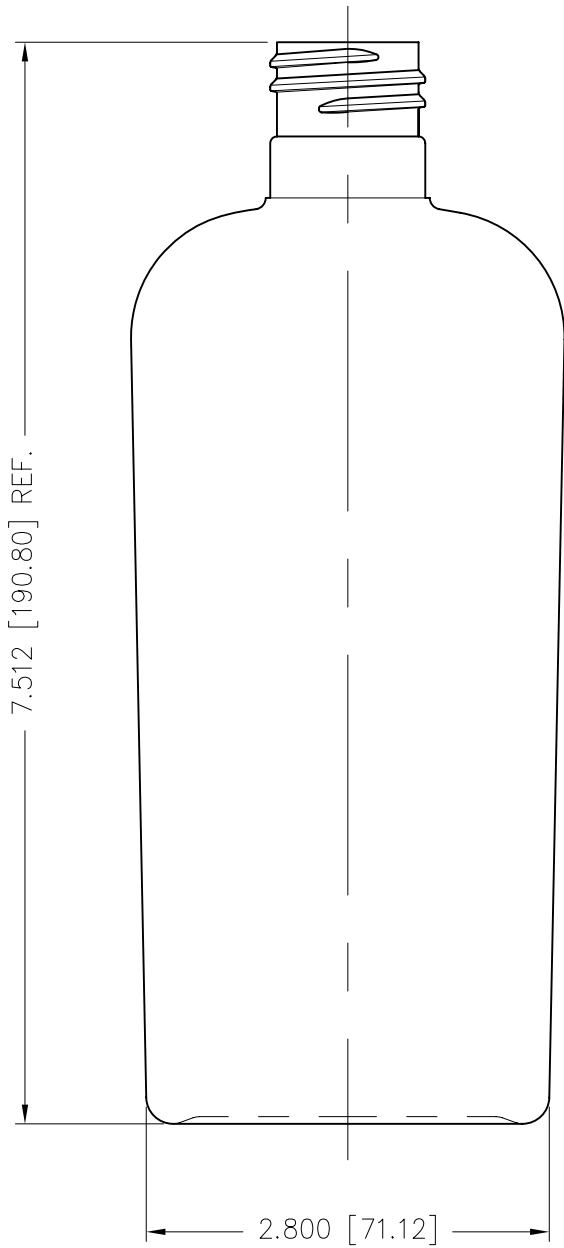

NECK FINISH:	M28-SP415	GRAM WEIGHT:	30.0g±2.0g
BOTTLE MAT.:	PVC	OVERFLOW:	402ml±11ml
DESC.	12oz. PVC VALE		



PROJECT NO.: 4-22202-P

SCALE: 3:4

REV.: D

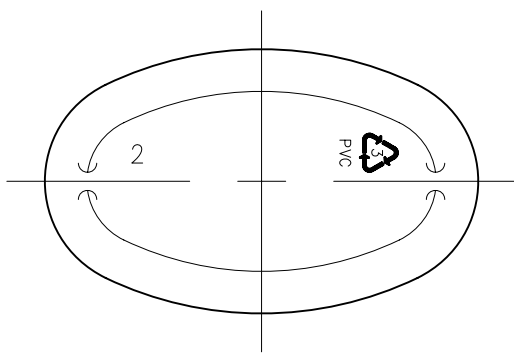
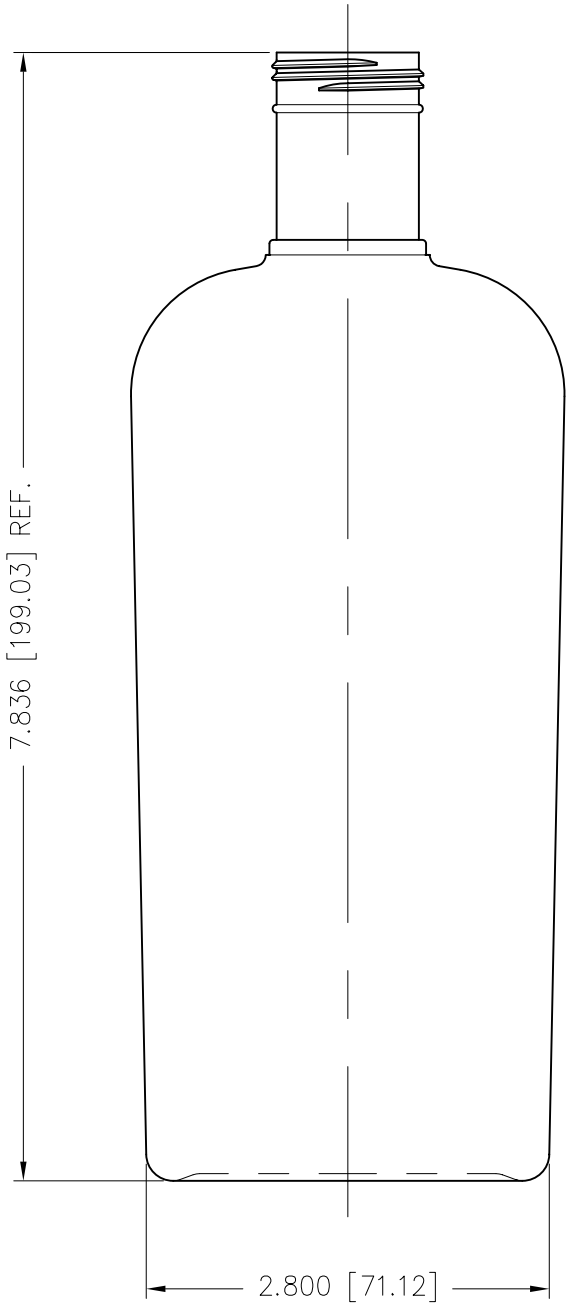

NECK FINISH:	M28 SEAQUIST	GRAM WEIGHT:	30.0g±2.0g
BOTTLE MAT.:	PVC	OVER FLOW:	402ml±11ml
DESC.	12oz. PVC VALE		



PROJECT NO.:	4-22202-P		
SCALE:	3:4	REV.:	D