

NECK FINISH: M28-SP400	GRAM WEIGHT: 12.0g±1.5g
BOTTLE MAT.: HDPE	OVER-FLOW: 140ml±5ml
DESC. 4oz. SQUAT CYL.	
PROJECT NO. 1-1814-P	
SCALE.: 1:1	REV.: B

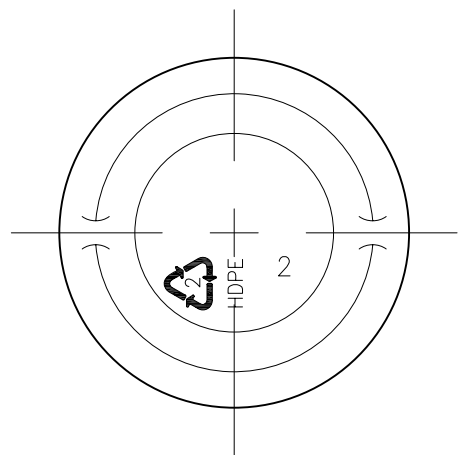
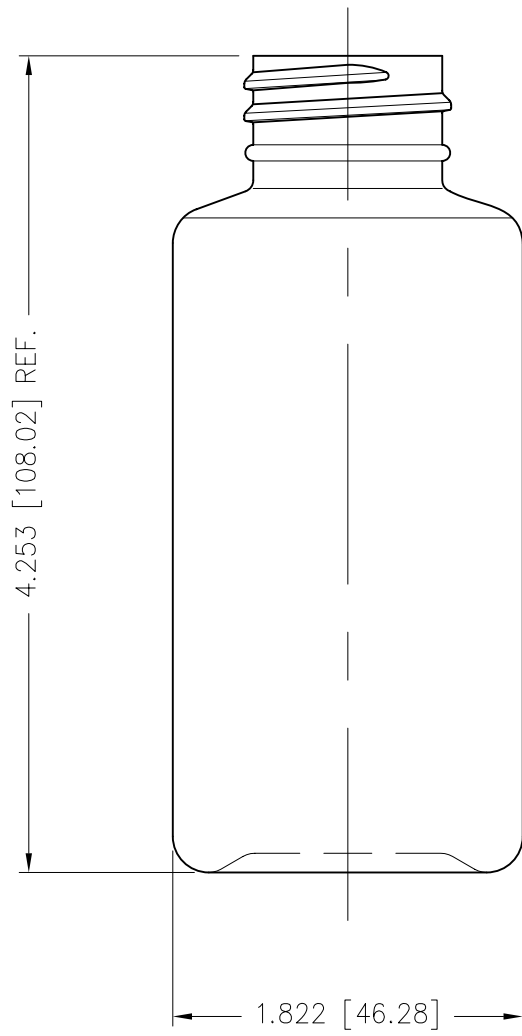

NECK FINISH:	M28-SP410	GRAM WEIGHT:	12.0g±1.5g
BOTTLE MAT.:	HDPE	OVER-FLOW:	144ml±5ml
DESC. 4oz. SQUAT CYL.			
PROJECT NO. 1-1814-P			
SCALE.: 1:1		REV.: B	